



Adjustable Steering Column 4 Post Overhead Guard 19.5kW AC Motor Ease of Access

SALES | SUPPORT | RENTAL

AISLE-MASTER

COUNTER BALANCE

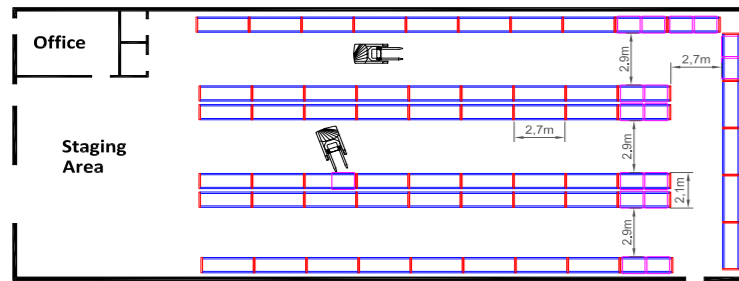

REACH TRUCK

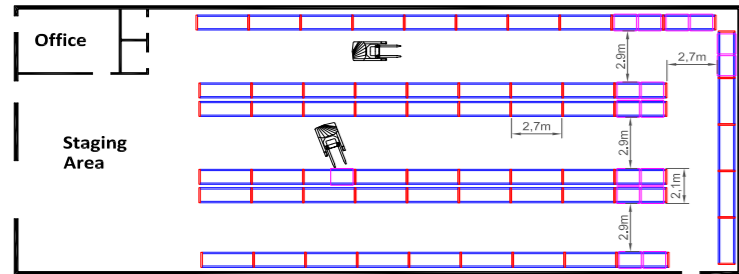

AISLE-MASTER
70% MORE than Counter Balance
30% MORE than Reach Truck

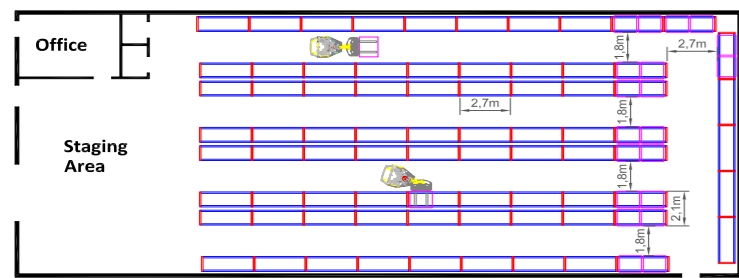

Stack to the Right



Straight a head



Stack to the Left



distributor

Aisle-Master Ltd.
 Gallinagh, Co. Monaghan
 Ireland

Tel: +353 47 80400 | Fax: +353 47 80402
 UK: 07870 976 758 | USA: 1877 266 2456
 Australia: 1300 369 899
 E-Mail: info@aisle-master.com
 Website: www.aisle-master.com

Increasing Storage-Reducing Costs



**5 YEARS/ 5,000 HOURS
 PARTS WARRANTY**



REDUCE AISLE WIDTHS
INCREASE STORAGE SPACE
CUT WAREHOUSING COSTS
IMPROVE PRODUCTIVITY

LPG | AC ELECTRIC

www.Aisle-Master.com

LPG | AC ELECTRIC

www.Aisle-Master.com

AISLE-MASTER... THE VERSATILE ARTICULATED TRUCK THAT DOES IT ALL



Battery Removal

Pedal- Footguard

Drinks Holder

Cab



12 m



Cold Storage Unit



Features & Benefits:

- Large super elastic tyres
- Robust chassis construction
- Integral side shift fitted as standard
- Two motors only. Traction & hydraulic
- 3000kg/6,000lbs Mast
- Low maintenance
- Indoor & outdoor
- Operator comfort and safety integral part of the machine
- Ergonomically designed to reduce fatigue and maximise visibility
- Full view of both the forks and the load
- Reduced load cycle times and product damage

REF.	MODEL	Metric			Imperial		
		15E	20SE	20WHE	33E	44SE	44WHE
	Description	Electric			Electric		
1	Lift Height	4750 mm	4750 mm	7050 mm	187"	187"	278"
2	Free Lift	1536 mm	1536 mm	2436 mm	61"	61"	96"
3	Closed Height	2398 mm	2398 mm	3298 mm	94"	94"	130"
4	Extended Height	5613 mm	5613 mm	7913 mm	221"	221"	312"
5	Mast Range	4300 - 6650 mm	4300 - 9050mm	7050 - 12400 mm	169"-262"	169"-356"	278"-488"
6	Overall Length	2780 mm	2780 mm	2780 mm	109"	109"	104 ½"
7	Ground Clearance		50 mm			2"	
8	Overhead Guard height		2270 mm			89 ½"	
9	Chassis Width Rear	1030 mm	1220 mm	1400 mm	40 ½"	48"	55"
10	Chassis Width Front		980 mm			39"	
11	Load Centre		500 mm			20"	
12	Wheel Base		1735 mm			68"	
13	Seat Height		1220 mm			48"	
14	Mast Tilt (back/fwd)		3° / 1°			3° / 1°	
15	Capacity	1500 kg	2000 kg	2000 kg	3300lbs	4400lbs	4400lbs
16	Ground Speed		16km/h			10mph	
17	Lift Speed (Laden/Unladen)		0.4 / 0.5 m/s			1.3 / 1.6 ft/s	
18	Front Tyre size		412 x 174 mm			16 ¼" x 7"	
19	Rear Tyre size		457 x 150 mm			18" x 6"	
20	Gradeability (Laden/Unladen)		12/15 %			12/15 %	
21	Battery Voltage/Capacity	48v / 620Ah	48v / 775 / 930 Ah		48v / 620Ah	48/775/930 Ah	
22	Weight of Truck less battery	5150 kg	5310 kg	5310 kg	11,350lbs	11,700lbs	11,700lbs
23	Weight of truck including the battery	6400 kg	6900 kg	6900 kg	14,100 lbs	15,210 lbs	15,210 lbs
24	Standard Colour		Yellow/Grey			Yellow/Grey	
25	Seat		KAB			KAB	

OPTIONAL LIFT HEIGHTS AND FORK LENGTHS AVAILABLE

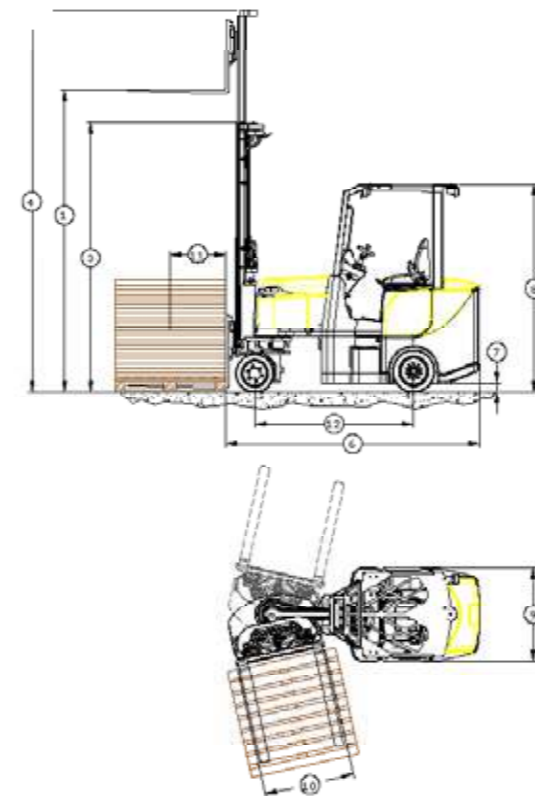

Features:

- AC Traction motor (19.5 kW)
- 775 Amp and 930 Amp hour capacity batteries
- Ergonomically designed operator's cab
- Full factory fitted customisations options available

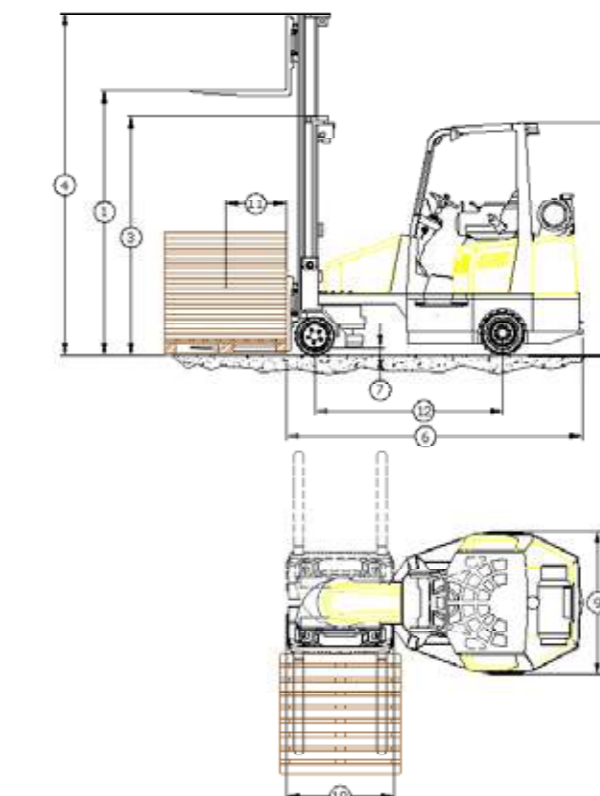

Features:

- Hydrostatic drive
- 3 Way catalytic converter fitted as standard
- Closed loop fuel system



Parts Warranty - 5 Years or 5,000 Hours (on major components and subject to conditions)

AC Electric

LP GAS