

# COMBi-GTE 3000-5500

The multi-directional forklift designed for the safe, space saving and productive handling of long and bulky loads.

# COMBiLiFT

LIFTING INNOVATION



# COMBi-GTE 3000-5500

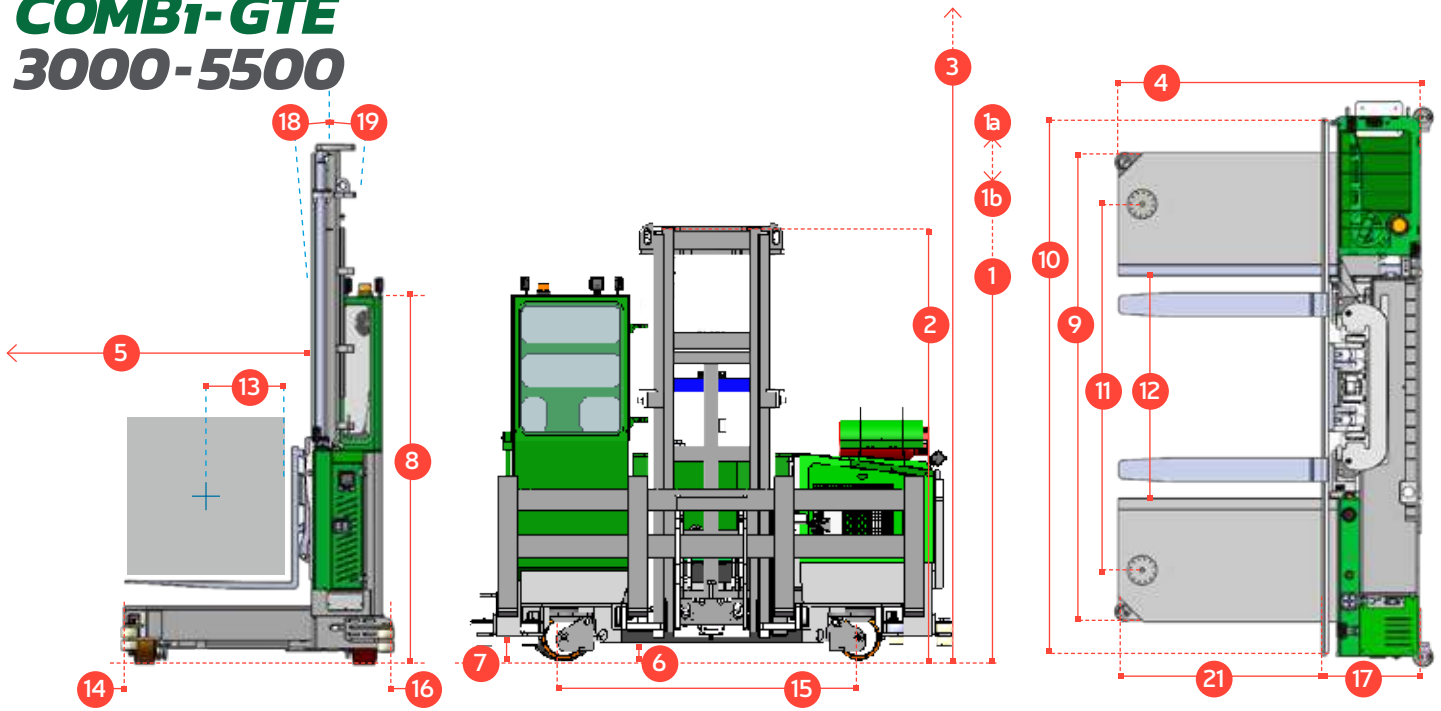

REF.	DESCRIPTION	3000 GTE	5500 GTE
1a	Standard Lift Height		5994mm
1b	Freelift Height		2489mm
2	Height Mast Closed		3988mm
3	Max. (Mast raised)		7086mm
4	Overall Length	1270mm	1372mm
5	Mast Travel		698.5mm
6	Ground Clearance Under Mast		127mm
7	Ground Clearance to Wheelbase		127mm
8	Height Over Cab (Without work lights)		2667mm
9	Width		2946mm
10	Outside Spread of Fork Arms		1346mm
11	Wheelbase		2286mm
12	Frame Opening		1397mm
13	Load Centre Distance		305mm
14	Overhang Front		152mm
15	Track		965mm
16	Overhang Back		140mm
17	Length From Face of Fork	660mm	762mm
18	Forward Tilt		3°
19	Backward Tilt		4 ½°
20	Platform Height (with front lowered)		406mm
21	Platform Length		609mm
22	Overall Width		3429mm
A	Capacity	3000 kg	5500 kg
B	Unladen Weight	9500 kg	10,500 kg
C	Maximum Ground Speed	11 km p/h	
D	Gradeability	10%	
E	Battery Capacity	72 V 560 Ah	
F	Fork Section	50 x 152.4 x 610	
G	350 / 150 - 280 Front Tire	OD 330mm / Width 152mm	
H	16 x 7 - 12 Rear Tire	OD 406mm / Width 177mm	
I	Standard Colour	Yellow & Grey	

## Multi-Directional

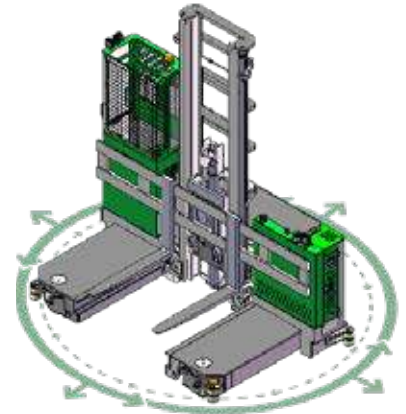

## Features Include:

- Rubber Mounted Overhead Guard
- 4 Wheel Steering
- Load Sensing Steering
- 2 Wheel Hydrostatic Drive
- Tilting Chassis +/- ½" at front
- Hydraulic Oil Cooler

## Optional:

- Wire Guidance
- Fold-up Forks

## Distributed by:

PCT Patent Application No. PCT/EP2014/053066; UK Patent Application No. GB1302811.3

COMBILIFT HAS A POLICY OF CONTINUOUS PRODUCT DEVELOPMENT AND RESERVES THE RIGHT TO ALTER SPECIFICATIONS WITHOUT PRIOR NOTICE. SPECIFICATIONS AND/OR DIMENSIONS MAY VARY FROM THOSE ILLUSTRATED IN SOME COUNTRIES.