

# GRENDIA EX

Diesel and LPG Counterbalance  
4 Wheel Pneumatic Tyres • 4.0 – 5.5 tonnes

FD40NB  
FG40N  
FD45NB  
FG45N  
FD50CNB  
FG50CN  
FD50NB  
FG50N  
FD55NB  
FG55N

## Built tough... built to last

**Tough, reliable and built to work as hard as you do, the class-leading GRENDIA EX promises reliable, class-leading performance - whatever the challenges. Tried and tested in the toughest applications, this no-nonsense design builds on the successes of its predecessors - delivering optimal performance.**

GRENDIA EX's sophisticated Euro 3B compliant engines, coupled with its long-life design, keeps GRENDIA's running costs and maintenance demands low - for maximum efficiency and productivity. Diesel models, for example, employ a unique, maintenance-free diesel particulate filter

that automatically burns off soot during operation... preventing downtime and delays.

Green inside and out, GRENDIA EX keeps noise and exhaust emissions to a minimum, while delivering improved overall economy. An optional Flex Control package - including wet disc brakes - offers further savings. It protects the transmission and prevents wheelspin, while its automatic adjustable braking reduces wear on brakes and 'hill hold' makes working on ramps and slopes quicker, safer and more comfortable.

### Frame and body

- **Stylish, purposeful design** reflects this machine's power to work productively, non-stop, whatever the conditions.
- **Robust construction** provides high stability, rigidity and protection, with no exposed wires or hoses.

### Mast and fork assembly

- **Strong, high-visibility mast** allows handling of heavy loads in tough environments with total confidence.
- **Wide range of high-quality masts and attachments** delivers precise compatibility and an ideal configuration for each application.

### Drive

- **Turbocharged diesel engine** delivers the power of a 5.0L engine, with the economy of a 3.4L engine, while meeting EURO Stage IIIB standards.
- **Maintenance-free diesel particulate filter** efficiently burns particulate matter while the truck is in operation - avoiding costly downtime.
- **Advanced LPG engine** with 3-way catalytic converter delivers precise, controlled performance and market-leading fuel economy with very low emissions.
- **Fully floating powertrain** with two-speed forward and one-speed reverse transmission maximises gradeability and travel speed, minimises noise and vibration, and uses maintenance-free gears instead of belts to lower running costs.
- **Adjustable transmission shift timing** increases versatility, for optimum performance in a wide variety of applications.
- **Large diameter drive axle shafts** are extremely durable and require little maintenance.



# GRENDIA EX

## Diesel Counterbalance

### 4 Wheel Pneumatic Tyres • 4.0 – 5.5 tonnes

Characteristics			Mitsubishi	Mitsubishi	Mitsubishi	Mitsubishi	Mitsubishi
1.1	Manufacturer (abbreviation)		Mitsubishi	Mitsubishi	Mitsubishi	Mitsubishi	Mitsubishi
1.2	Manufacturer's model designation		FD40NB	FD45NB	FD50CNB	FD50NB	FD55NB
1.3	Power source: (battery, diesel, LP gas, petrol)		Diesel	Diesel	Diesel	Diesel	Diesel
1.4	Operator type: pedestrian, (operator)-standing, -seated		Seated	Seated	Seated	Seated	Seated
1.5	Load capacity	Q kg	4000	4500	5000	5000	5500
1.6	Load center distance	c (mm)	500	500	500	600	600
1.8	Load distance, axle to fork face	x (mm)	577	577	582	602	602
1.9	Wheelbase	y (mm)	1850	2000	2000	2150	2150
Weight							
2.1	Truck weight, without load / including battery (simplex mast, lowest lift height)	kg	5920	6330	6850	7300	7640
2.2	Axle loading with maximum load, front/rear (simplex mast, lowest lift height)	kg	8960 / 960	9710 / 1130	10600 / 1250	11020 / 1280	11740 / 1400
2.3	Axle loading without load, front/rear (simplex mast, lowest lift height)	kg	2630 / 3290	2780 / 3550	2900 / 3950	3220 / 4080	3170 / 4470
Wheels, Drive Train							
3.1	Tyres: V=solid, L=pneumatic, SE=solid pneumatic - front/rear		L / L	L / L	L / L	L / L	SE / SE
3.2	Tyre dimensions, front		8,25-15-14PR	300-15-18PR	300-15-18PR	300-15-18PR	300-15/8,00
3.3	Tyre dimensions, rear		7,00-12-14PR	7,00-12-14PR	7,00-12-14PR	7,00-12-14PR	7,00-12/5,00
3.5	Number of wheels, front/rear (x=driven)		2x/2	2x/2	2x/2	2x/2	2x/2
3.6	Track width (center of tyres), front	b10 (mm)	1175	1175	1175	1175	1175
3.7	Track width (center of tyres), rear	b11 (mm)	1180	1180	1180	1180	1180
Dimensions							
4.1	Mast tilt, forwards/backwards	a/b °	6/12	6/12	6/12	6/12	6/12
4.2	Height with mast lowered (see tables)	h1 (mm)	2320	2320	2400	2400	2400
4.3	Free lift (see tables)	h2 (mm)	150	150	150	160	160
4.4	Lift height (see tables)	h3 (mm)	3300	3300	3300	3300	3300
4.5	Overall height with mast raised	h4 (mm)	3920	3920	4000	4000	4000
4.7	Height to top of overhead guard	h6 (mm)	2296	2296	2296	2296	2296
4.8	Seat height	h7 (mm)	1082	1082	1082	1082	1082
4.12	Tow coupling height	h10 (mm)	395	395	395	395	395
4.19	Overall length	l1 (mm)	4220	4350	4390	4530	4580
4.20	Length to fork face (includes fork thickness)	l2 (mm)	3000	3130	3170	3310	3360
4.21	Overall width	b1/b2 (mm)	1415 / 1965	1460 / 1965	1460 / 1965	1460 / 1965	1460 / 1965
4.22	Fork dimensions (thickness, width, length)	s / e / l (mm)	50 / 150 / 1220	50 / 150 / 1220	50 / 150 / 1220	60 / 150 / 1220	60 / 150 / 1220
4.23	Fork carriage to DIN 15 173 A/B/no		3A	3A	3A	4A	4A
4.24	Fork carriage width	b3 (mm)	1190	1190	1190	1190	1190
4.31	Ground clearance under mast, with load	m1 (mm)	150	150	150	150	150
4.32	Ground clearance at center of wheelbase, with load (forks lowered)	m2 (mm)	227	227	227	227	227
4.33	Working aisle width with 1000 x1200 mm pallets, crosswise	Ast (mm)	4357	4507	4542	4692	4742
4.34a	Working aisle width with 800 x1200 mm pallets, lengthwise	Ast (mm)	4157	4307	4342	4492	4542
4.35	Turning circle radius	Wa (mm)	2580	2730	2760	2890	2940
4.36	Minimum distance between centers of rotation	b13 (mm)	836	903	903	971	971
Performance							
5.1	Travel speed, with/without load	km/h	19,5/20,5	19,5 / 20,5	19,5 / 20,5	19,0 / 20,0	19,0 / 20,0
5.2	Lifting speed, with/without load	m/s	0.55 / 0.61	0.55 / 0.61	0.47 / 0.53	0.47 / 0.53	0.47 / 0.53
5.3	Lowering speed, with/without load	m/s	0.50 / 0.50	0.50 / 0.50	0.50 / 0.50	0.50 / 0.50	0.50 / 0.50
5.5	Rated drawbar pull, with/without load	N	27000 / 17400	27000 / 18700	26500 / 19400	26500 / 21800	26000 / 21300
5.7	Gradeability, with/without load	%	29 / 26	26 / 27	24 / 26	23 / 27	21 / 25
5.9	Acceleration time (10 metres) with/without load	s	-/-	-/-	-/-	-/-	-/-
5.10	Service brakes (mechanical/hydraulic/electric/pneumatic)		Hydraulic	Hydraulic	Hydraulic	Hydraulic	Hydraulic
IC Engine							
7.1	Manufacturer / Type		854F	854F	854F	854F	854F
7.2	Rated / Nominal output to ISO 1585	kW	55	55	55	55	55
7.3	Rated speed to DIN 70 020	rpm	2200	2200	2200	2200	2200
7.4	Number of cylinders / cubic capacity	cm3	4 / 3400	4 / 3400	4 / 3400	4 / 3400	4 / 3400
7.5	Fuel consumption according to VDI 60 cycle	l/h / kg/h	*	*	*	*	*
7.6	Max torque	Nm	260	260	260	260	260
7.7	Max torque at engine speed	rpm	1000	1000	1000	1000	1000
Miscellaneous							
8.1	Type of drive control		Powershift 2/1	Powershift 2/1	Powershift 2/1	Powershift 2/1	Powershift 2/1
8.2	Maximum operating pressure for attachments	bar	191	191	191	191	191
8.3	Oil flow for attachments	l/min	80	80	80	80	80
8.4	Noise level, value at operator's ear (EN 12053)	dB(A)	84	84	84	84	84
8.5	Towing coupling design / DIN type, ref.		Pin	Pin	Pin	Pin	Pin

\* On request



Clear-view overhead guard

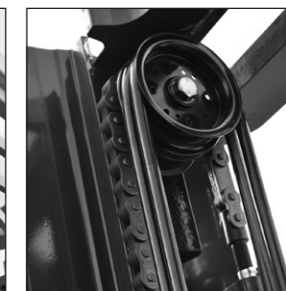

Robust mast assembly

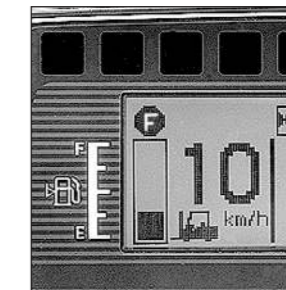

Informative LCD display



Fully hydrostatic steering

## GRENDIA THE GREEN DIAMOND

The green colour of our trucks is a sign of our commitment to protecting the environment.

The diamond shapes in our logo are a reminder that – like a diamond – a Mitsubishi forklift truck guarantees quality, reliability and a sound investment.

Continuing improvement may lead to changes in these specifications.

## LPG Counterbalance

### 4 Wheel Pneumatic Tyres • 4.0 – 5.5 tonnes

Characteristics			Mitsubishi	Mitsubishi	Mitsubishi	Mitsubishi	Mitsubishi
1.1	Manufacturer (abbreviation)		FG40N	FG45N	FG50CN	FG50N	FG55N
1.2	Manufacturer's model designation		LPG	LPG	LPG	LPG	LPG
1.3	Power source: (battery, diesel, LP gas, petrol)		Seated	Seated	Seated	Seated	Seated
1.4	Operator type: pedestrian, (operator)-standing, -seated		Q	kg	4000	4500	5000
1.5	Load capacity		c	(mm)	500	500	600
1.6	Load center distance		x	(mm)	577	577	602
1.8	Load distance, axle to fork face		y	(mm)	1850	2000	2000
1.9	Wheelbase				2000	2150	2150
Weight							
2.1	Truck weight, without load / including battery (simplex mast, lowest lift height)	kg	5860	6270	6780	7240	7570
2.2	Axle loading with maximum load, front/rear (simplex mast, lowest lift height)	kg	8940 / 920	9680 / 1090	10570 / 1210	10990 / 1250	11710 / 1360
2.3	Axle loading without load, front/rear (simplex mast, lowest lift height)	kg	2610 / 3250	2750 / 3520	2870 / 3920	3190 / 4050	3130 / 4440
Wheels, Drive Train							
3.1	Tyres: V=solid, L=pneumatic, SE=solid pneumatic - front/rear		L / L	L / L	L / L	L / L	SE / SE
3.2	Tyre dimensions, front		8,25-15-14PR	300-15-18PR	300-15-18PR	300-15-18PR	300-15/8,00
3.3	Tyre dimensions, rear		7,00-12-14PR	7,00-12-14PR	7,00-12-14PR	7,00-12-14PR	7,00-12/5,00
3.5	Number of wheels, front/rear (x=driven)		2x/2	2x/2	2x/2	2x/2	2x/2
3.6	Track width (center of tyres), front	b10 (mm)	1175	1175	1175	1175	1175
3.7	Track width (center of tyres), rear	b11 (mm)	1180	1180	1180	1180	1180
Dimensions							
4.1	Mast tilt, forwards/backwards	a/b °	6/12	6/12	6/12	6/12	6/12
4.2	Height with mast lowered (see tables)	h1 (mm)	2320	2320	2400	2400	2400
4.3	Free lift (see tables)	h2 (mm)	150	150	160	160	160
4.4	Lift height (see tables)	h3 (mm)	3300	3300	3300	3300	3300
4.5	Overall height with mast raised	h4 (mm)	3920	3920	4000	4000	4000
4.7	Height to top of overhead guard	h6 (mm)	2296	2296	2296	2296	2296
4.8	Seat height	h7 (mm)	1082	1082	1082	1082	1082
4.12	Tow coupling height	h10 (mm)	395	395	395	395	395
4.19	Overall length	l1 (mm)	4220	4350	4390	4530	4580
4.20	Length to fork face (includes fork thickness)	l2 (mm)	3000	3130	3170	3310	3360
4.21	Overall width	b1/b2 (mm)	1415 / 1965	1460 / 1965	1460 / 1965	1460 / 1965	1460 / 1965
4.22	Fork dimensions (thickness, width, length)	s / e / l (mm)	50 / 150 / 1220	50 / 150 / 1220	50 / 150 / 1220	60 / 150 / 1220	60 / 150 / 1220
4.23	Fork carriage to DIN 15 173 A/B/no		3A	3A	3A	4A	4A
4.24	Fork carriage width	b3 (mm)	1190	1190	1190	1190	1190
4.31	Ground clearance under mast, with load	m1 (mm)	150	150	150	150	150
4.32	Ground clearance at center of wheelbase, with load (forks lowered)	m2 (mm)	227	227	227	227	227
4.33	Working aisle width with 1000 x1200 mm pallets, crosswise	Ast (mm)	4357	4507	4542	4692	4742
4.34a	Working aisle width with 800 x1200 mm pallets, lengthwise	Ast (mm)	4157	4307	4342	4492	4542
4.35	Turning circle radius	Wa (mm)	2580	2730	2760	2890	2940
4.36	Minimum distance between centers of rotation	b13 (mm)	836	903	903	971	971
Performance							
5.1	Travel speed, with/without load	km/h	22.0 / 22.5	22.0 / 22.5	22.0 / 22.5	22.0 / 22.5	21.5 / 22.5
5.2	Lifting speed, with/without load	m/s	0.57 / 0.60	0.57 / 0.60	0.49 / 0.52	0.49 / 0.52	0.49 / 0.52
5.3	Lowering speed, with/without load	m/s	0.50 / 0.50	0.50 / 0.50	0.50 / 0.50	0.50 / 0.50	0.50 / 0.50
5.5	Rated drawbar pull, with/without load	N	28000 / 17200	27500 / 18500	27500 / 19200	27000 / 21600	27000 / 21000
5.7	Gradeability, with/without load	%	30 / 26	27 / 26	25 / 25	23 / 26	22 / 25
5.9	Acceleration time (10 metres) with/without load	s	-/-	-/-	-/-	-/-	-/-
5.10	Service brakes (mechanical/hydraulic/electric/pneumatic)		Hydraulic	Hydraulic	Hydraulic	Hydraulic	Hydraulic
IC Engine							
7.1	Manufacturer / Type		TB45	TB45	TB45	TB45	TB45
7.2	Rated / Nominal output to ISO 1585	kW	72	72	72	72	72
7.3	Rated speed to DIN 70 020	rpm	2450	2450	2450	2450	2450
7.4	Number of cylinders / cubic capacity	cm3	6 / 4500	6 / 4500	6 / 4500	6 / 4500	6 / 4500
7.5	Fuel consumption according to VDI 60 cycle	l/h / kg/h	*	*	*	*	*
7.6	Max torque	Nm	280	280	280	280	280
7.7	Max torque at engine speed	rpm	1200	1200	1200	1200	1200
Miscellaneous							
8.1	Type of drive control		Powershift 2/1	Powershift 2/1	Powershift 2/1	Powershift 2/1	Powershift 2/1
8.2	Maximum operating pressure for attachments	bar	191	191	191	191	191
8.3	Oil flow for attachments	l/min	80	80	80	80	80
8.4	Noise level, value at operator's ear (EN 12053)	dB(A)	84	84	84	84	84
8.5	Towing coupling design / DIN type, ref.		Pin	Pin	Pin	Pin	Pin

\* On request

Continuing improvement may lead to changes in these specifications.

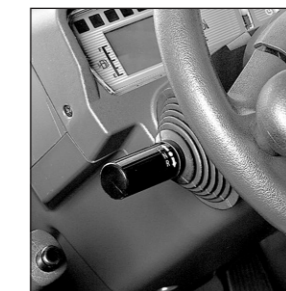

Auto-style controls



Adjustable steering column



Grip/horn for reversing (optional)

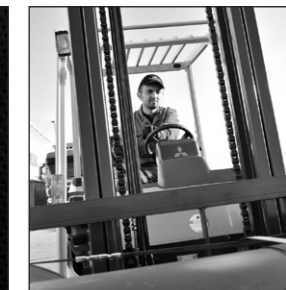

High all-round visibility

## GRENDIA THE GREEN DIAMOND

The green colour of our trucks is a sign of our commitment to protecting the environment.

The diamond shapes in our logo are a reminder that – like a diamond – a Mitsubishi forklift truck guarantees quality, reliability and a sound investment.

# GRENDIA EX

## FD/FG40-45N(B) Models

Mast Performance and Capacity

FD40NB / FG40N & FD45NB / FG45N													
Mast type	h3 mm	h1 mm	h4 mm	h2 mm	h5 mm	FD/FG40N(B)	FD/FG40N(B)	FD/FG45N(B)	FD/FG45N(B)	FD/FG40N(B)	FD/FG40N(B)	FD/FG45N(B)	FD/FG45N(B)
						Q@ c=500mm (pneumatic) kg	Q@ c=600mm (pneumatic) kg	Q@ c=500mm (pneumatic) kg	Q@ c=600mm (pneumatic) kg	Q@ c=500mm (solid pneum.) kg	Q@ c=600mm (solid pneum.) kg	Q@ c=500mm (solid pneum.) kg	Q@ c=600mm (solid pneum.) kg
Simplex	3000	2170	4130	150	-	4000	3500	4500	4000	4000	3500	4500	4000
	3300	2320	4430	150	-	4000	3500	4500	4000	4000	3500	4500	4000
	3700	2520	4830	150	-	4000	3500	4500	4000	4000	3500	4500	4000
	4000	2700	5130	150	-	4000	3500	4500	4000	4000	3500	4500	4000
	4500	3000	5630	150	-	4000	3500	4500	4000	4000	3500	4500	4000
	5000	3250	6130	150	-	3850	3500	4500	4000	4000	3500	4500	4000
	5500	3500	6630	150	-	3600	3400*	4300*	4000*	3700	3500	4400	4000
6000	3750	7130	150	-	3500*	3300*	3900*	3900*	3600	3400	4250	3900	
Duplex	3000	2170	4130	-	1090	4000	3500	4500	4000	4000	3500	4500	4000
	3300	2320	4430	-	1240	4000	3500	4500	4000	4000	3500	4500	4000
	3700	2520	4830	-	1440	4000	3500	4500	4000	4000	3500	4500	4000
	4100	2700	5190	-	1620	4000	3500	4500	4000	4000	3500	4500	4000
Triplex	3700	1950	4830	-	870	4000	3500	4500	4000	4000	3500	4500	4000
	4000	2050	5130	-	970	4000	3500	4500	4000	4000	3500	4500	4000
	4360	2170	5490	-	1090	4000	3500	4500	4000	4000	3500	4500	4000
	4700	2285	5830	-	1200	3900	3500	4500	4000	4000	3500	4500	4000
	5050	2400	6180	-	1320	3800	3500	4500	4000	3900	3500	4500	4000
	5500	2550	6630	-	1470	3600*	3400*	4200*	4000*	3700	3450	4350	4000
	6000	2750	7130	-	1670	3450*	3250*	4050*	3800*	3550	3300	4200	3900
	6500	2950	7630	-	1870	3000*	3000*	3000*	3000*	3350	3200	4050*	3800*
7000	3150	8130	-	2070	2400*	2400*	2400*	2400*	3300*	3100*	3500*	3500*	

\* Truck equipped with dual tyres. Consult your dealer for the maximum back-tilt allowed, to obtain the capacities specified.

# GRENDIA EX

## FD/FG50CN(B) Models

Mast Performance and Capacity

FD50CNB / FG50CN									
Mast type	h3 mm	h1 mm	h4 mm	h2 mm	h5 mm	FD/FG50CN(B)	FD/FG50CN(B)	FD/FG50CN(B)	FD/FG50CN(B)
						Q@ c=500mm (pneumatic) kg	Q@ c=600mm (pneumatic) kg	Q@ c=500mm (solid pneum.) kg	Q@ c=600mm (solid pneum.) kg
Simplex	3000	2250	4130	150	-	5000	4500	5000	4500
	3300	2400	4430	150	-	5000	4500	5000	4500
	3700	2600	4830	150	-	5000	4500	5000	4500
	4000	2850	5130	150	-	5000	4500	5000	4500
	4500	3100	5630	150	-	5000	4500	5000	4500
	5000	3350	6130	150	-	5000	4500	5000	4500
	5500	3600	6630	150	-	4750*	4500*	4850	4500
6000	3850	7130	150	-	3900*	3900*	4700	4400	
Duplex	3000	2250	4100	-	1170	5000	4500	5000	4500
	3300	2400	4410	-	1320	5000	4500	5000	4500
	4100	2850	5210	-	1770	5000	4500	5000	4500
Triplex	3700	2050	4830	-	970	5000	4500	5000	4500
	4040	2170	5170	-	1090	5000	4500	5000	4500
	4310	2260	5440	-	1180	5000	4500	5000	4500
	4750	2400	5880	-	1320	5000	4500	5000	4500
	5050	2500	6180	-	1420	5000	4500	5000	4500
	5500	2650	6630	-	1570	4700*	4450*	4800	4500
	6000	2850	7130	-	1770	4200*	4200*	4600	4350
	6500	3050	7630	-	1970	3000*	3000*	4450*	4200
7000	3250	8130	-	2170	2400*	2400*	3500*	3500	



Fingertip hydraulic controls (optional)



Front LED working lights



Stylish, robust design

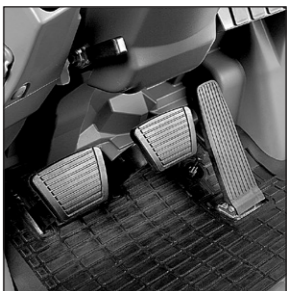

Auto-style pedals

# GRENDIA EX

## FD/FG40-45(C)N(B) Models

Capacities at Various Load Centres

Simplex - h3 = 4000 mm

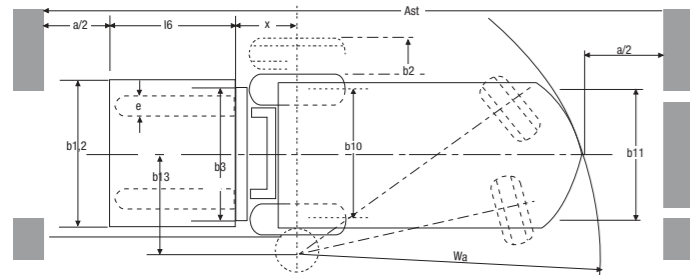
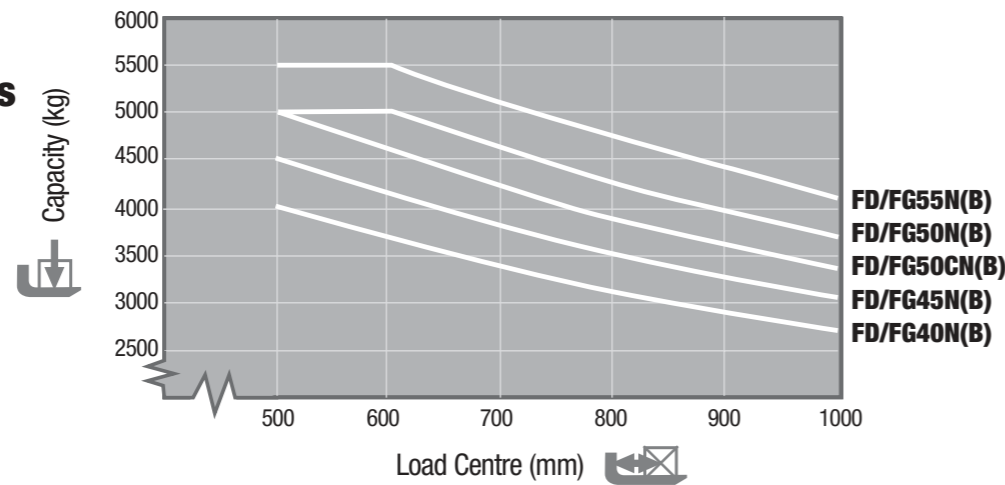

- h1 Height with mast lowered
- h2 Standard free lift
- h3 Lift height
- h4 Height with mast raised
- h5 Full free lift
- Q Lifting capacity, rated load
- c Load centre (distance)
- Ast = Working aisle width
- Wa = Turning radius
- a = Safety clearance = 2 x 100 mm
- l6 = Pallet length
- b12 = Pallet width

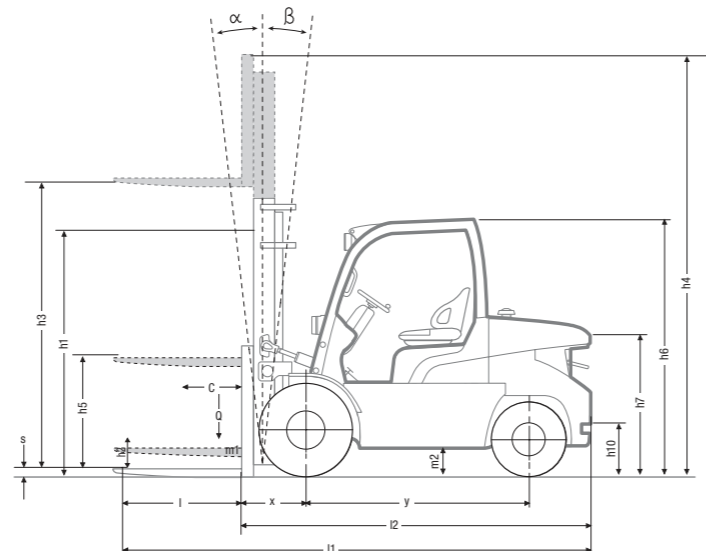

# GRENDIA EX

## FD/FG50-55N(B) Models

Mast Performance and Capacity

FD50NB / FG50N & FD55NB / FG55N									
Mast type	h3 mm	h1 mm	h4 mm	h2 mm	h5 mm	FD/FG50N(B)	FD/FG55N(B)	FD/FG50N(B)	FD/FG55N(B)
						Q@ c=600mm (pneumatic) kg	Q@ c=600mm (pneumatic) kg	Q@ c=600mm (solid pneum.) kg	Q@ c=600mm (solid pneum.) kg
Simplex	3000	2250	4280	160	-	5000	5500	5000	5500
	3300	2400	4580	160	-	5000	5500	5000	5500
	3700	2600	4980	160	-	5000	5500	5000	5500
	4000	2850	5280	160	-	5000	5500	5000	5500
	4500	3100	5780	160	-	5000	5500	5000	5500
	5000	3350	6280	160	-	5000	5500*	5000	5500
	5500	3600	6780	160	-	4900*	(4650)*	5000	5500
6000	3850	7280	160	-	4100*	(3450)*	4900	5350*	
Duplex	3000	2250	4250	-	1030	5000	5500	5000	5500
	3300	2400	4560	-	1180	5000	5500	5000	5500
	4100	2850	5360	-	1630	5000	5500	5000	5500
Triplex	3700	2050	4980	-	830	5000	5500	5000	5500
	4040	2170	5320	-	950	5000	5500	5000	5500
	4310	2260	5590	-	1040	5000	5500	5000	5500
	4750	2400	6030	-	1180	5000	5450	5000	5500
	5050	2500	6330	-	1280	5000	5500*	5000	5500
	5500	2650	6780	-	1430	4900*	-	5000	5500
6000	2850	7280	-	1630	4300*	-	4800*	5300*	

\* Truck equipped with dual tyres. Consult your dealer for the maximum back-tilt allowed, to obtain the capacities specified.



Convenient handbrake button



Advanced LPG technology



User-friendly hydraulic levers

### Steering system

- **Fully hydrostatic steering system** - together with compact design - ensures effortless, precise and responsive manoeuvring - even in tight spaces.
- **Angle-sensitive steering system** provides quick turning at low speeds and precision control at higher speeds.

### Brakes

- **Powerful drum brake system** gives excellent control with little effort and is easy to maintain.
- **Electronically controlled parking brake** allows safe, effective immobilisation of the truck with minimum effort - and without restricting knee and leg movement.

### Hydraulics

- **Powerful hydraulic system** is specifically designed to minimise noise in the operator's environment.

### Electrical and control systems

- **Integrated Presence System 2 (IPS2)** pioneered by Mitsubishi prevents all movement of the truck and its mast if the operator is not seated.
- **Operator identification system** can be activated - if owner wishes - to prevent unauthorised use of the truck.
- **Onboard diagnostics** and detailed fault diagnosis via laptop connection alerts operators and service engineers to problems, speeds up servicing and prevents damage.

### Operator compartment and controls

- **Market-leading ErgoCentric design** results in easy on-off access, a unique, adjustable steering column with position memory, user-friendly controls, a practical layout and great all-round visibility - for maximum precision and productivity.
- **Full-suspension seat** with hip support keeps driver comfortable through the longest of shifts.
- **Hydraulic control levers** are easy to reach and easy to use.
- **Optional fingertip hydraulic controls** with integrated, fully adjustable, high-comfort armrest (an award-winning concept) allows effortless precision.
- **Automotive-style pedals** with optimum pedal angle are easy to use and give good control without leg strain.
- **Low noise level at operator's ear** and low vibration from powertrain increases comfort and reduces fatigue.
- **Clear and comprehensive instrument panel** with LCD display keeps operator and manager fully informed of, for example, speed, time, engine hours, service intervals and faults - to optimise productivity, truck life and safety.

### Other features

- **Long service interval** and long life of components reduces downtime and associated costs.
- **RapidAccess features** give unequalled ease of entry to all areas for checks and maintenance.
- **Optimal air filter placement** means that filter cartridge replacement is minimised.
- **Belly Seal protects** against damaging dust and debris - preventing the 'cyclone effect' where dust and dirt is drawn into the engine and recirculated into the working environment.

### Options

- **FlexControl intelligent truck protection package**
- **Fingertip hydraulic controls**
- **Rear grip with integrated horn button**
- **Load weight indicator**
- **Overload indicator**
- **Wide range of lighting options**
- **Choice of forks**
- **Integral sideshifter**
- **Choice of carriages**
- **Oil-cooled wet disc brakes**
- **ProShift transmission protection**
- **Fully adjustable armrest**

# when reliability is everything...

Like any product bearing the Mitsubishi name, our materials handling equipment benefits from the huge resources and cutting-edge technology of one of the world's largest corporations. So when we promise you **quality, reliability** and **value for money**, you know it's a guarantee we have the power to deliver.

Every model in our comprehensive, award-winning range of forklift trucks and warehouse equipment is built to a high specification and is designed to keep on working for you... day after day... year after year... whatever the job... whatever the conditions.

To ensure your truck stays in constant productive action, we have a network of local dealers - hand-picked for their commitment to customer care... and backed up by the Mitsubishi Forklift Trucks organisation. No matter where you are, we have a dealer close by - ready and willing to meet your needs.

That friendly local service covers everything from identifying the perfect model and configuration for your application to providing competitive, flexible finance and maintenance packages, unbeatable warranties, long and short term hire, and highly responsive field service and repairs... as well as the industry's quickest and most reliable parts supply.

Only Mitsubishi can give you this combination of global engineering excellence and outstanding local support... only Mitsubishi offers you such a quality product at such an affordable price... and only Mitsubishi places reliability as high as you do in its priorities. Contact your local dealer now and see what Mitsubishi can do for you.

You can find your nearest dealer at [www.mitforklift.com](http://www.mitforklift.com)



### FlexControl intelligent truck protection:

- combined with oil-cooled wet disc brakes in an option package for high-intensity applications
- delivers dynamic performance with minimum wear of transmission components and tyres



### Integrated Presence System 2 (IPS2) provides:

- a hydraulic and travel interlock system that prevents all movement of the truck and its mast if the driver is not seated
- a seat belt warning light
- an automatic parking brake with alarm

The term 'Integrated Presence System' (IPS) is intended as a trading style, only to describe a number of design features on the Mitsubishi trucks to which IPS is applied. It does not imply that the truck can be driven without appropriate operator training and without due care and attention. The manufacturer (MCFE, Almere, the Netherlands) cannot accept any responsibility for any accidents or damage caused by incorrect or dangerous use of its equipment.



CESM 1758v2 (10/16)  
© 2016 MCFE  
Printed in The Netherlands

[mitforklift@mcf.nl](mailto:mitforklift@mcf.nl) [www.mitforklift.com](http://www.mitforklift.com)

NOTE: Performance specifications may vary depending on standard manufacturing tolerances, vehicle condition, types of tyres, floor or surface conditions, applications or operating environment. Trucks may be shown with non-standard options. Specific performance requirements and locally available configurations should be discussed with your distributor of Mitsubishi forklift trucks. Mitsubishi follows a policy of continual product improvement. For this reason, some materials, options and specifications could change without notice.