

ELEVIA

VNT11-20(XL) Series

VNA TRUCKS

1.1 – 2.0 tonnes

**BIG PERFORMANCE...
IN SMALL SPACES**

A true VNA specialist, the ELEVIA series is optimised for easy order picking and pallet handling in narrow aisle spaces.

SPECIFICATIONS

VNT11	VNT15
VNT12	VNT15XL*
VNT13	VNT20*
VNT14	



**WHEN
RELIABILITY IS
EVERYTHING...**

ELEVIA

VNT11-20(XL) Series

VNA TRUCKS

1.1 – 2.0 tonnes

With intuitive controls, an ergonomic, spacious cabin and excellent visibility, ELEVIA is an operator's dream. Modular design and engineering make it highly configurable.

Each model in the range is fully optimised for a specific type of application, making for a comprehensive and versatile selection of trucks. The 1.1–1.3-tonne models are available with 48v or 80v electrical systems, while larger models are 80v only.

DRIVE

- **Adjustable load wheel height** allows a single wheel - rather than all wheels - to be changed if damaged.

FRAME AND BODY

- **Optimised body design** resulting in less load, less wear, less energy consumption and higher performance.
- **Guide rollers in front of load wheels** to ensure optimal guidance and prevent damage to the load wheels.
- **Easy access to battery** for quick changes.
- **Short truck length** ideal for small transfer aisles.

MAST AND FORK ASSEMBLY

- **Duplex mast available for all lifting heights** for added stability, lower energy consumption, and higher lifting speed.
- **Highly optimised mast** using the FEM method to achieve the ideal stability and weight.
- **High visibility mast** affording the operator excellent forward vision.

BRAKES

- **Low centre of gravity and low vehicle weight** mean no need for a load wheel brake and fewer parts to service.

ELECTRICAL AND CONTROL SYSTEMS

- **Separate valve to regulate cabin lifting** for lower energy consumption and fewer parts to replace compared to an 'energy recovery' system.
- **Fast error analysis without a computer** thanks to LEDs on the state-of-the-art microcontrollers.
- **In-depth diagnostics** available via GSM-connection / computer connection by USB (or optional CAN-bus connection).

OPERATOR COMPARTMENT AND CONTROLS

- **Spacious operator cabin** with plenty of leg room to suit operators of all sizes.
- **Narrow rail at the front of cabin** makes order picking easy.
- **Tilting side gates (option)** help with order picking as operator can reach up to 20 cm further into the shelf.
- **Five different control panels available** allowing your operators to have a familiar setup.
- **Control panel can be placed for standing or sitting operation** for optimal ergonomics during a shift.
- **Velour-covered cabin walls and thick cushioned floor** make for a more comfortable environment for operators.

- **Overhead guard has 4 LED spotlights and compartment for emergency rope** for added safety.
- **Choice of seats** with features including air-cushioning, adjustable lumbar support, downward-folding cushion and standing operator back support.
- **Tilting console as an option** can be swivelled left or right for easier front access and order picking.
- **Clear graphics display** makes key information easy to read.

OTHER FEATURES

- **Can be lowered and driven at a height of 2400mm** for convenient transportation.
- **Can be equipped with telescopic fork**



There is more information on ELEVIA on mitforklift.com

For more extensive information please visit our website mitforklift.com



* VNT15XL and VNT20 models are available on request for specific applications. 19 metre lift height is only possible with VNT15XL

VDI - PERFORMANCE & DIMENSIONS

ELEVIA

VNT11-14 Series VNA TRUCKS

1.1 – 1.4 tonnes



VNT14

CHARACTERISTICS				Mitsubishi Forklift Trucks	Mitsubishi Forklift Trucks	Mitsubishi Forklift Trucks	Mitsubishi Forklift Trucks
1.1	Manufacturer			VNT11	VNT12	VNT13	VNT14
1.2	Manufacturer's model designation			Battery	Battery	Battery	Battery
1.3	Power source			Standing / Seated	Standing / Seated	Standing / Seated	Standing / Seated
1.4	Operator type			1100	1200	1300	1350
1.5	Load capacity	Q	kg	600	600	600	600
1.6	Load center distance	c	mm	1780	1845	1910	1880
1.9	Wheelbase	y	mm				
WEIGHT							
2.1	Truck weight, without load / including battery (simple x mast, lowest lift height)		kg	4900 - 5600	4950 - 5800	5050 - 5900	5800 - 6900
2.2	Axle loading with maximum load, front / rear (simple x mast, lowest lift height)		kg	1600/4400; 1850/4850	1650/4500; 1900/5100	1700/4650; 2000/5200	1800/5300; 2050/6150
2.3	Axle loading without load, front / rear (simple x mast, lowest lift height)		kg	2100/2800; 2400/3200	2150/2800; 2450/3350	2250/2800; 2550/3350	2400/3400; 2700/4200
WHEELS, DRIVE TRAIN							
3.1	Tyres: PT = Power Thane, Vul = Vulkollan, P = Polyurethane, N = Nylon, R = Rubber drive / load side			P	P	P	P
3.2	Tyre dimensions, drive side		mm	343 / 140	343 / 140	343 / 140	343 / 140
3.3	Tyre dimensions, load side		mm	343 / 140	343 / 140	343 / 140	377 / 178
3.5	Number of wheels, load / drive side (x = driven)			2 / 1 x	2 / 1 x	2 / 1 x	2 / 1 x
DIMENSIONS							
4.2a	Height with mast lowered	h1	mm	See table	See table	See table	See table
4.5	Height with mast extended	h4	mm	See table	See table	See table	See table
4.7	Height to top of overhead guard	h6	mm	See table	See table	See table	See table
4.8	Seat- or stand height	h7	mm	See table	See table	See table	See table
4.11	Supplementary lift	h9	mm	1900	1900	1900	1900
4.14	Platform height, raised	h12	mm	See table	See table	See table	See table
4.15	Fork height, fully lowered	h13	mm	90	90	90	90
4.22	Fork dimensions (thickness, width, length)	s / e / l	mm	40 / 120 / 800 - 1300	40 / 120 / 800 - 1300	40 / 120 / 800 - 1300	40 / 120 / 800 - 1300
4.25	Outside width over forks (minimum / maximum)	b5	mm	530 / 505 - 795	530 / 505 - 795	530 / 505 - 795	530 / 505 - 795
4.32	Ground clearance at center of wheelbase, (forks lowered)	m2	mm	40	40	40	40
4.33a	Working aisle width (Ast) with 1000 x 1200 mm pallets, load crosswise	Ast	mm	See table	See table	See table	See table
4.34a	Working aisle width (Ast) with 800 x 1200 mm pallets, load lengthwise	Ast	mm	See table	See table	See table	See table
4.35	Turning radius	Wa	mm	2080	2145	2210	2170
PERFORMANCE							
5.1	Travel speed, with / without load		km/h	12.0 / 12.0	12.0 / 12.0	12.0 / 12.0	12.0 / 12.0
5.2	Lifting speed, with / without load		m/s	0.32 / 0.40 ¹⁾	0.31 / 0.40 ¹⁾	0.52 / 0.56 ¹⁾	0.49 / 0.52 ¹⁾
5.3	Lowering speed, with / without load		m/s	0.45 / 0.45	0.45 / 0.45	0.45 / 0.45	0.45 / 0.45
5.4	Reach speed with/without load		m/s	up to 0.45 ⁴⁾	up to 0.45 ⁴⁾	up to 0.45 ⁴⁾	up to 0.45 ⁴⁾
5.10	Service brakes (mechanical / hydraulic / electric / pneumatic)			Electric	Electric	Electric	Electric
ELECTRIC MOTORS							
6.1	Drive motor		kW	5.0	5.0	7.0	7.0
6.2	Lift motor		kW	12.5 ¹⁾	12.5 ¹⁾	21.0 ¹⁾	21.0 ¹⁾
6.4	Battery voltage/capacity at 5-hour discharge		V/Ah	48 / 775 ²⁾³⁾	48 / 930 ²⁾³⁾	80 / 620 ³⁾	80 / 465 ³⁾
6.5	Battery weight		kg	1118	1309	1558	1238
MISCELLANEOUS							
8.1	Type of drive control			Stepless	Stepless	Stepless	Stepless

1) Higher lift speeds on request

2) Also available in 80 volt

3) Other capacities on request

4) Adjustable

OTHER DIMENSIONS				VNT11	VNT12	VNT13	VNT14
T1	Overhang	x / x1	mm	355 / 255	355 / 255	355 / 255	355 / 255
T2	Picking height		mm	h12 + 1600	h12 + 1600	h12 + 1600	h12 + 1600
T3	Overall width (in 50 mm steps)	b1	mm	1000 - 1700	1200 - 1700	1200 - 1700	1200 - 1700
T4	Overall length with fork carrier width 850 mm	l1	mm	3275 - 3365 - 3465	3335 - 3425 - 3525	3400 - 3490 - 3590	3375 - 3465 - 3565
T5	Overall length with fork carrier width 580 mm	l1	mm	3140 - 3230 - 3330	3200 - 3290 - 3390	3265 - 3355 - 3455	3240 - 3330 - 3430
T6	Support boom length (standard)	M1S	mm	460 - 550 - 650	460 - 550 - 650	460 - 550 - 650	460 - 550 - 650

VDI - PERFORMANCE & DIMENSIONS

CHARACTERISTICS				Mitsubishi Forklift Trucks	Mitsubishi Forklift Trucks	Mitsubishi Forklift Trucks
1.1	Manufacturer			VNT15	VNT15XL	VNT20
1.2	Manufacturer's model designation			Battery	Battery	Battery
1.3	Power source			Standing / Seated	Standing / Seated	Standing / Seated
1.4	Operator type			1500	1500	2000
1.5	Load capacity	Q	kg	600	600	600
1.6	Load center distance	c	mm	2140	2140	2140
1.9	Wheelbase	y	mm			
WEIGHT						
2.1	Truck weight, without load / including battery (simple x mast, lowest lift height)		kg	7100 - 8700	8900 - 9400	7400 - 8900
2.2	Axle loading with maximum load, front / rear (simple x mast, lowest lift height)		kg	2300/6300; 2950/7250	3000/7400; 3100/7800	2100/7300; 2700/8200
2.3	Axle loading without load, front / rear (simple x mast, lowest lift height)		kg	2900/4200; 3550/5150	3500/5400; 3700/5700	3000/4400; 3400/5400
WHEELS, DRIVE TRAIN						
3.1	Tyres: PT = Power Thane, Vul = Vulkollan, P = Polyurethane, N = Nylon, R = Rubber drive / load side			P	P	P
3.2	Tyre dimensions, drive side		mm	381 / 152	381 / 152	381 / 152
3.3	Tyre dimensions, load side		mm	377 / 178	377 / 178	377 / 178
3.5	Number of wheels, load / drive side (x = driven)			2 / 1 x	2 / 1 x	2 / 1 x
DIMENSIONS						
4.2a	Height with mast lowered	h1	mm	See table	See table	See table
4.5	Height with mast extended	h4	mm	See table	See table	See table
4.7	Height to top of overhead guard	h6	mm	See table	See table	See table
4.8	Seat- or stand height	h7	mm	See table	See table	See table
4.11	Supplementary lift	h9	mm	1900	1900	1500
4.14	Platform height, raised	h12	mm	See table	See table	See table
4.15	Fork height, fully lowered	h13	mm	90	90	90
4.22	Fork dimensions (thickness, width, length)	s / e / l	mm	40 / 120 / 800 - 1300	40 / 120 / 800 - 1300	40 / 120 / 800 - 1300
4.25	Outside width over forks (minimum / maximum)	b5	mm	530 / 505 - 795	530 / 505 - 795	240 - 795
4.32	Ground clearance at center of wheelbase, (forks lowered)	m2	mm	40	40	40
4.33a	Working aisle width (Ast) with 1000 x 1200 mm pallets, load crosswise	Ast	mm	See table	See table	See table
4.34a	Working aisle width (Ast) with 800 x 1200 mm pallets, load lengthwise	Ast	mm	See table	See table	See table
4.35	Turning radius	Wa	mm	2445	2445	2445
PERFORMANCE						
5.1	Travel speed, with / without load		km/h	12.0 / 12.0	12.0 / 12.0	12.0 / 12.0
5.2	Lifting speed, with / without load		m/s	0.48 / 0.52 ¹⁾	0.44 / 0.52	0.48 / 0.56
5.3	Lowering speed, with / without load		m/s	0.45 / 0.45	0.45 / 0.45	0.45 / 0.45
5.4	Reach speed with/without load		m/s	up to 0.45 ⁴⁾	up to 0.45 ⁴⁾	0.20 / 0.20
5.10	Service brakes (mechanical / hydraulic / electric / pneumatic)			Electric	Electric	Electric
ELECTRIC MOTORS						
6.1	Drive motor		kW	7.0	7.0	7.0
6.2	Lift motor		kW	21.0 ¹⁾	32.0	32.0 ¹⁾
6.4	Battery voltage/capacity at 5-hour discharge		V/Ah	80 / 775 ³⁾	80 / 775 ³⁾	80 / 775 ³⁾
6.5	Battery weight		kg	1862	1862	1862
MISCELLANEOUS						
8.1	Type of drive control			Stepless	Stepless	Stepless

- 1) Higher lift speeds on request
- 2) Also available in 80 volt
- 3) Other capacities on request
- 4) Adjustable

OTHER DIMENSIONS				VNT15	VNT15XL	VNT20
T1	Overhang	x / x1	mm	360 / 270	360 / 270	360 / 270
T2	Picking height		mm	h12 + 1600	h12 + 1600	h12 + 1600
T3	Overall width (in 50 mm steps)	b1	mm	1200 - 1700	1600 - 1900	1200 - 1700
T4	Overall length with fork carrier width 850 mm	l1	mm	3650 - 3740 - 3840	3650 - 3740 - 3840	3740 - 3840
T5	Overall length with fork carrier width 580 mm	l1	mm	3515 - 3605 - 3705	3515 - 3605 - 3705	3605 - 3705
T6	Support boom length (standard)	M1S	mm	460 - 550 - 650	460 - 550 - 650	550 - 650

ELEVIA

VNT15-20(XL) Series VNA TRUCKS

1.5 – 2.0 tonnes



VNT15XL

MAST PERFORMANCE AND CAPACITY

ELEVIA VNT11-20(XL) Series

Build and lift heights of duplex lift mast with swivel fork, supplementary lift 1900 mm or 2300 mm (optional)

Total lift height with 1900 mm suppl. lift	Total lift height with 2300 mm suppl. lift	Cabin lift height	Raised platform height	Extended height cabin**	VNT11 - VNT13	VNT14/ VNT15	VNT15XL	VNT20
					Closed height 2-stage mast*	Closed height 2-stage mast*	Closed height 2-stage mast	Closed height 2-stage mast**
h3G+h13 mm	h3G+h13 mm	h3+h13 mm	h12 mm	h6 mm	h1 mm	h1 mm	h1 mm	h1 mm
4400	4800	2500	2820	5020	2495	-	-	-
4900	5300	3000	3320	5520	2745	-	-	-
5400	5800	3500	3820	6020	2995	2920	-	3170
5900	6300	4000	4320	6520	3245	3170	-	3420
6400	6800	4500	4820	7020	3495	3420	-	3670
6900	7300	5000	5320	7520	3745	3670	-	3920
7400	7800	5500	5820	8020	3995	3920	-	4170
7900	8300	6000	6320	8520	4245	4170	-	4420
8400	8800	6500	6820	9020	4495	4420	-	4670
8900	9300	7000	7320	9520	4745	4670	-	4920
9400	9800	7500	7820	10020	4995	4920	-	5170
9900	10300	8000	8320	10520	5245	5170	-	5420
10400	10800	8500	8820	11020	-	5420	-	5670
10900	11300	9000	9320	11520	-	5670	-	5920
11400	11800	9500	9820	12020	-	5920	-	6170
11900	12300	10000	10320	12520	-	6170	-	6420
12400	12800	10500	10820	13020	-	6420	-	6670
12900	13300	11000	11320	13520	-	6670	-	6920
13400	13800	11500	11820	14020	-	6920	-	7170
13900	14300	12000	12320	14520	-	7170	7420	-
14400	14800	12500	12820	15020	-	-	7670	-
14900	15300	13000	13320	15520	-	-	7920	-
15400	15800	13500	13820	16020	-	-	8170	-
15900	16300	14000	14320	16520	-	-	8420	-

*VNT11 maximum closed height 4745 mm; *VNT14 maximum closed height 6170 mm; other closed/lift heights on request.

**Extended height with 2300 mm suppl. lift + 600 mm;

***VNT20 reduced total lift heights, supplementary lift = 1500 mm; other heights on request.

Build and lift heights of triplex lift mast with swivel fork, supplementary lift 1900 mm or 2300 mm (optional)

Total lift height with 1900 mm suppl. lift	Total lift height with 2300 mm suppl. lift	Cabin lift height	Raised platform height	Extended height cabin**	VNT11 - VNT13	VNT14/ VNT15	VNT15XL
					Closed height 3-stage mast*	Closed height 3-stage mast*	Closed height 3-stage mast
h3G+h13 mm	h3G+h13 mm	h3+h13 mm	h12 mm	h6 mm	h1 mm	h1 mm	h1 mm
5650	6050	3750	4070	6270	2495	-	-
6400	6800	4500	4820	7020	2745	-	-
7150	7550	5250	5570	7770	2995	2920	-
7900	8300	6000	6320	8520	3245	3170	-
8650	9050	6750	7070	9270	3495	3420	-
9400	9800	7500	7820	10020	3745	3670	-
10150	10550	8250	8570	10770	3995	3920	-
10900	11300	9000	9320	11520	-	4170	-
11650	12050	9750	10070	12270	-	4420	-
12400	12800	10500	10820	13020	-	4670	4920
13150	13550	11250	11570	13770	-	4920	5170
13900	14300	12000	12320	14520	-	5170	5420
14650	15050	12750	13070	15270	-	5420	5670
15400	15800	13500	13820	16020	-	-	5920
16150	16550	14250	14570	16770	-	-	6170

*VNT11 maximum closed height 3495 mm; **extended height with 2300 mm suppl. lift + 400 mm; other closed/lift heights on request. Overall length with triplex mast: VNT11/12/13 is 35 mm longer; VNT14/15 is 125 mm longer; VNT14 closed height > 4170 mm same length as VNT15.

Aisle width depending on load / pallet dimensions

LOAD DIMENSIONS				VNT11	VNT12/ VNT13	VNT14	VNT15/ VNT20
Depth	Width	Distance between loads**	Boom length	Transfer aisle width*	Transfer aisle width*	Transfer aisle width*	Transfer aisle width*
mm	mm	Ast mm	M15 mm	mm	mm	mm	mm
1240	835	1700	460	3480	3530	3595	3820
1200	800	1650	460	3460	3510	3575	3800
1200	1000	1650	550	3540	3600	3655	3890
1200	1200	1650	650	3630	3690	3745	3980
1000	800	1450	460	3380	3440	3495	3730
1000	1000	1450	550	3460	3520	3585	3820
1000	1200	1450	650	3560	3610	3675	3910
800	800	1400	460	3360	3420	3485	3710
800	1000	1400	550	3450	3500	3565	3800
800	1200	1400	650	3540	3600	3655	3900
835	1240	1400	650	3540	3600	3655	3900

*Transfer aisle width without load and 580 mm fork carriage width, with mechanical guidance + 300 mm, with wire guidance + 800 mm recommended.

Aisle width for mechanical guidance and duplex mast; reduced truck lengths on request.

** VNT20 + 50 mm.

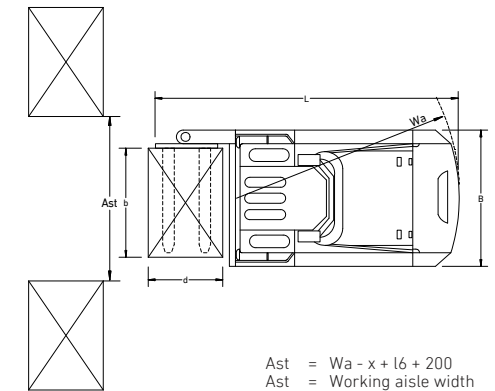
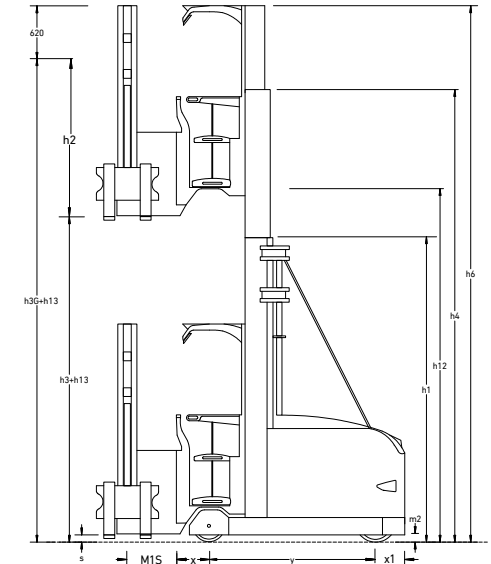

Ast = $Wa - x + l6 + 200$
Ast = Working aisle width
Wa = Turning radius

STANDARD EQUIPMENT & OPTIONS

● = Standard

● = Option

	VNT11	VNT12	VNT13	VNT14	VNT15	VNT15XL	VNT20
GENERAL							
Overhead guard with 4 LED spot	●	●	●	●	●	●	●
Mirrors	●	●	●	●	●	●	●
Emergency rope	●	●	●	●	●	●	●
Control panel with ball handle bar	●	●	●	●	●	●	●
Higher side shift speed	●	●	●	●	●	●	●
CHASSIS							
Special paint, change of one colour (Standard RAL)	●	●	●	●	●	●	●
Extended or shortened chassis	●	●	●	●	●	●	●
Twin/dual load wheels, minimum chassis width 1450 mm	●	●	●	●	●	●	●
VNT14 with VNT15 chassis, battery up to 5 PzS 700/775 Ah	●	●	●	●	●	●	●
VNT15 with chassis for battery 6 PzS 840/930 Ah, special drive wheel	●	●	●	●	●	●	●
Rail guidance for standard profile, minimum 80 mm profile height	●	●	●	●	●	●	●
Rail guidance, minimum 38 mm profile height	●	●	●	●	●	●	●
Side guide rollers antistatic	●	●	●	●	●	●	●
Additional side guide roller in the centre of truck (3 rollers on each side)	●	●	●	●	●	●	●
Inductive wire guidance 6.25 kHz +/- 30 Hz, 78 mA	●	●	●	●	●	●	●
Line driver for max 1200 m wire, 6.25 kHz	●	●	●	●	●	●	●
MAST							
Fork carriage width 850 mm	●	●	●	●	●	●	●
Fork carriage width 1150 mm	●	●	●	●	●	●	●
Head centre distance 700 mm (less capacity)	●	●	●	●	●	●	●
Head centre distance 750/800 mm (less capacity)	●	●	●	●	●	●	●
Shorten mast, special closed heights	●	●	●	●	●	●	●
Full fork carriage for swivel fork 320, 850 mm for distance across forks 240 - 795 mm	●	●	●	●	●	●	●
Hydraulic fork adjustment, 500 - 800 mm, integrated, width of fork carriage 1080 mm	●	●	●	●	●	●	●
Side shifter +/- 100 mm	●	●	●	●	●	●	●
Telescopic fork, width 1200 mm, supplementary lift 650 mm	●	●	●	●	●	●	●
Telescopic fork, width 1200 mm, supplementary lift > 650 mm	●	●	●	●	●	●	●
Telescopic fork, width 1200 mm, supplementary lift > 650 mm, profiles in front of the load, max 1000 kg, no cold store	●	●	●	●	●	●	●
Telescopic forks, lowered height 190 mm, max capacity 1000 kg	●	●	●	●	●	●	●
Supplementary lift height 1700 mm with swivel fork type MSG 320	●	●	●	●	●	●	●
Supplementary lift height 2100 or 2300 mm with swivel fork type MSG 320	●	●	●	●	●	●	●
VNT15 with swivel fork type MSG 120, supplementary lift 1500 mm	●	●	●	●	●	●	●
VNT15 with swivel fork type MSG 120, guidance at overhead guard, supplementary lift 1500 mm	●	●	●	●	●	●	●
CABIN							
Control panel with rotary switches	●	●	●	●	●	●	●
Control panel with single lever	●	●	●	●	●	●	●
Control panel with multifunction lever	●	●	●	●	●	●	●
Tilting panel for order picking (only possible with ball handle bar or rotary switch)	●	●	●	●	●	●	●
Spilt control panel at the back, beside the seat, including armrests	●	●	●	●	●	●	●
Multicheck with PIN-code access, 10 different codes, hour counter for week and day	●	●	●	●	●	●	●
12 or 24 volt connection with separate DC converter	●	●	●	●	●	●	●
24 volt connection behind ignition lock, max 2 ampere	●	●	●	●	●	●	●

ELEVIA

VNT11-20(XL) Series

VNA TRUCKS

1.1 – 2.0 tonnes



Overhead guard with 4 LED spot



Control panel with ball handle bar



Telescopic fork

STANDARD EQUIPMENT & OPTIONS

● = Standard
● = Option

	VNT11	VNT12	VNT13	VNT14	VNT15	VNT15XL	VNT20
Armrests, adjustable	●	●	●	●	●	●	●
Heated seat	●	●	●	●	●	●	●
Air suspension seat	●	●	●	●	●	●	●
Swivel seat	●	●	●	●	●	●	●
2 additional LED working lights at both sides of the overhead guard	●	●	●	●	●	●	●
2 powerful LED lighting strips at left and right side of overhead guard	●	●	●	●	●	●	●
Flashing light at the mast	●	●	●	●	●	●	●
Blue spot at the mast to the rear, functioning when travelling backwards	●	●	●	●	●	●	●
Simultaneous lifting of main and supplementary lift	●	●	●	●	●	●	●
Clipboard DIN A4 in the cabin	●	●	●	●	●	●	●
Clipboard DIN A4 at universal fastening rail	●	●	●	●	●	●	●
Height level positioning system (10 levels) with indicator, for cabin lift (not together with PIN-code system)	●	●	●	●	●	●	●
Overload indicator	●	●	●	●	●	●	●
Digital scale, +/- 25 kg, measurement by hydraulic pressure of supplementary lift mast	●	●	●	●	●	●	●
Fan in cabin	●	●	●	●	●	●	●
Swivel /tilting side gates, specially for order picking	●	●	●	●	●	●	●
Tray for universal fastening rail	●	●	●	●	●	●	●
Acoustic signal when driving backwards	●	●	●	●	●	●	●
Speed control unit GSG2 for linear driving speeds depending on lift height, programmable lift stop above 500 mm	●	●	●	●	●	●	●
Windscreen removable	●	●	●	●	●	●	●
Makrolon screen on the overhead guard	●	●	●	●	●	●	●
Makrolon window in front of the control panel (only for EK 1500 with swivel fork type 120)	●	●	●	●	●	●	●
Makrolon cabin, windscreen removable	●	●	●	●	●	●	●
Cabin heating	●	●	●	●	●	●	●
INTERLOCKS							
Slow down at the end of aisle, without stop (system MFT)	●	●	●	●	●	●	●
Slow down and stop at the end of aisle (system MFT)	●	●	●	●	●	●	●
Magnets per aisle	●	●	●	●	●	●	●
Electrical drive and lift cut-out with overriding switch	●	●	●	●	●	●	●
Electrical drive and lift cut-out with overriding switch outside the aisle	●	●	●	●	●	●	●
Electrical reach cut-out for swivel head MSG 320	●	●	●	●	●	●	●
Zone-dependent interlocks	●	●	●	●	●	●	●
Driving outside the guidance up to maximum lift height with override switch, 2.5 km/h, drive wheel in straight position	●	●	●	●	●	●	●
BATTERY							
Battery frame additional for fast and easy battery change with counterbalance truck	●	●	●	●	●	●	●
Battery rollers in truck 48 V 6 PzS/80 V 3 PzS	●	●	●	●	●	●	●
Battery roller station for 1 battery 48 V 6 PzS/80 V 3 PzS for fixing on floor	●	●	●	●	●	●	●
Battery Rollers in truck 80 V 5 PzS	●	●	●	●	●	●	●
Battery Roller Station for 1 battery 80 V 5 PzS for fixing on floor	●	●	●	●	●	●	●
Mobile winch for battery change for fixing at the chassis	●	●	●	●	●	●	●
Battery cable for battery changing	●	●	●	●	●	●	●
COLD STORE							
Cold store application, without cabin	●	●	●	●	●	●	●
Cabin for cold store applications	●	●	●	●	●	●	●
Inductive wire guidance 6.25 kHz +/- 30 Hz, 78 mA +/- 15%, Zapi	●	●	●	●	●	●	●
Lifting jack for relieving the driving wheel when battery is loading	●	●	●	●	●	●	●
48/80 volt supply for the night (converter not for cold store area, without cable)	●	●	●	●	●	●	●
Telescopic forks for cold store application	●	●	●	●	●	●	●
SAFETY							
Preparation for installing personal safety system with laser scanner	●	●	●	●	●	●	●
Personal safety system with 2 laser scanner, SSZ (including preparation)	●	●	●	●	●	●	●

ELEVIA

VNT11-20(XL) Series

VNA TRUCKS

1.1 – 2.0 tonnes



Dual load wheels



Spilt control panel, including armrests



Fan in cabin

WHEN RELIABILITY IS EVERYTHING...



ELEVIA
RULE THE AISLES

Built from the ground up with narrow aisles in mind, the ELEVIA range is the last word in small-space productivity.

In tight spaces our VNA trucks thrive. Whether picking or stacking, their high performance and robust build never comes up short.

Like any product bearing the "MITSUBISHI" name our materials handling equipment benefits from the tremendous heritage, huge resources and cutting-edge technology of one of the world's largest corporations – Mitsubishi Heavy Industries Group.

Engineering spacecraft, jet planes, power plants and more, MHI specialises in those technologies where performance, dependability and superiority decide your success or failure...

So when we promise you quality, reliability and value for money, you know it's a guarantee we have the power to deliver.

That's why every model in our award-winning and comprehensive range of lift trucks and warehouse equipment is built to a high specification – to ensure it keeps working for you. Day after day. Year after year. Whatever the job. Whatever the conditions.

YOU'LL NEVER WORK ALONE

As your local authorised dealer, we are here to keep your trucks working – through our extensive experience, our technical excellence and our commitment to customer care.

We are your local experts, backed by efficient channels to the entire organisation of Mitsubishi Forklift Trucks.

No matter where you are, we are close by – with the capability to meet your needs.

Discover how Mitsubishi Forklift Trucks give you more from your local authorised dealer or when you visit our website www.mitforklift.com

Performance specifications may vary depending on standard manufacturing tolerances, vehicle condition, types of tyres, floor or surface conditions, applications or operating environment. Trucks may be shown with non-standard options. Specific performance requirements and locally available configurations should be discussed with your distributor of Mitsubishi forklift trucks. We follow a policy of continual product improvement. For this reason, some materials, options and specifications could change without notice.

info@mitforklift.com

WESM2012 (04/20) © 2021 MLE

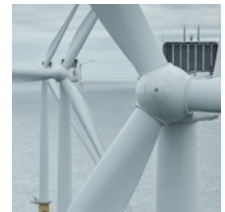

Mitsubishi Logisnext Europe B.V.
Hefbrugweg 77, 1332 AM Almere
The Netherlands
Tel: +31 (0)36 5494 411



mft2.eu/fb



mft2.eu/apps



mft2.eu/youtube



mft2.eu/facebook

